



# ITM

# 2024

İSTANBUL

# ADVERTISING AREAS

[www.itmexhibition.com](http://www.itmexhibition.com)

---

# CONTENTS

## B

### Outdoor Ads Area

Flagpoles .....	6
Flagpoles .....	7
Flagpoles .....	8
Visitor Service Area Billboards.....	9
East Car Park Billboard .....	10
Outer Court Columns Wrappings .....	11
Megaboard.....	12
Visitor Entrance Billboards .....	13
Visitor Entrance Billboard .....	14

# C

## Indoor Ads

Column Wrapping .....	18
Column Wrapping .....	19
Column Wrapping .....	20
Illuminated Wall Panels .....	21
Hanging Banners Above Booths .....	22
Exhibition Hall Main Entrance Special Advertising Areas.....	23
Indoor Area Allocation Plan Logo Ads .....	24
Hall Entrance Advertising Panels.....	25
Column Wrapping .....	26
LCD Screens .....	27
Textile Box Advertising Boards .....	28
Illuminated Wall Panels .....	30
Foyer Ceiling-Hang Ads .....	31
Illuminated Wall Panels .....	32
Jet Pass Kiosk Advertisements .....	33

# D

## Ads on Printed Materials

Catalogue Ads .....	34
Visitor Guide - Exhibition Layout Ads .....	35

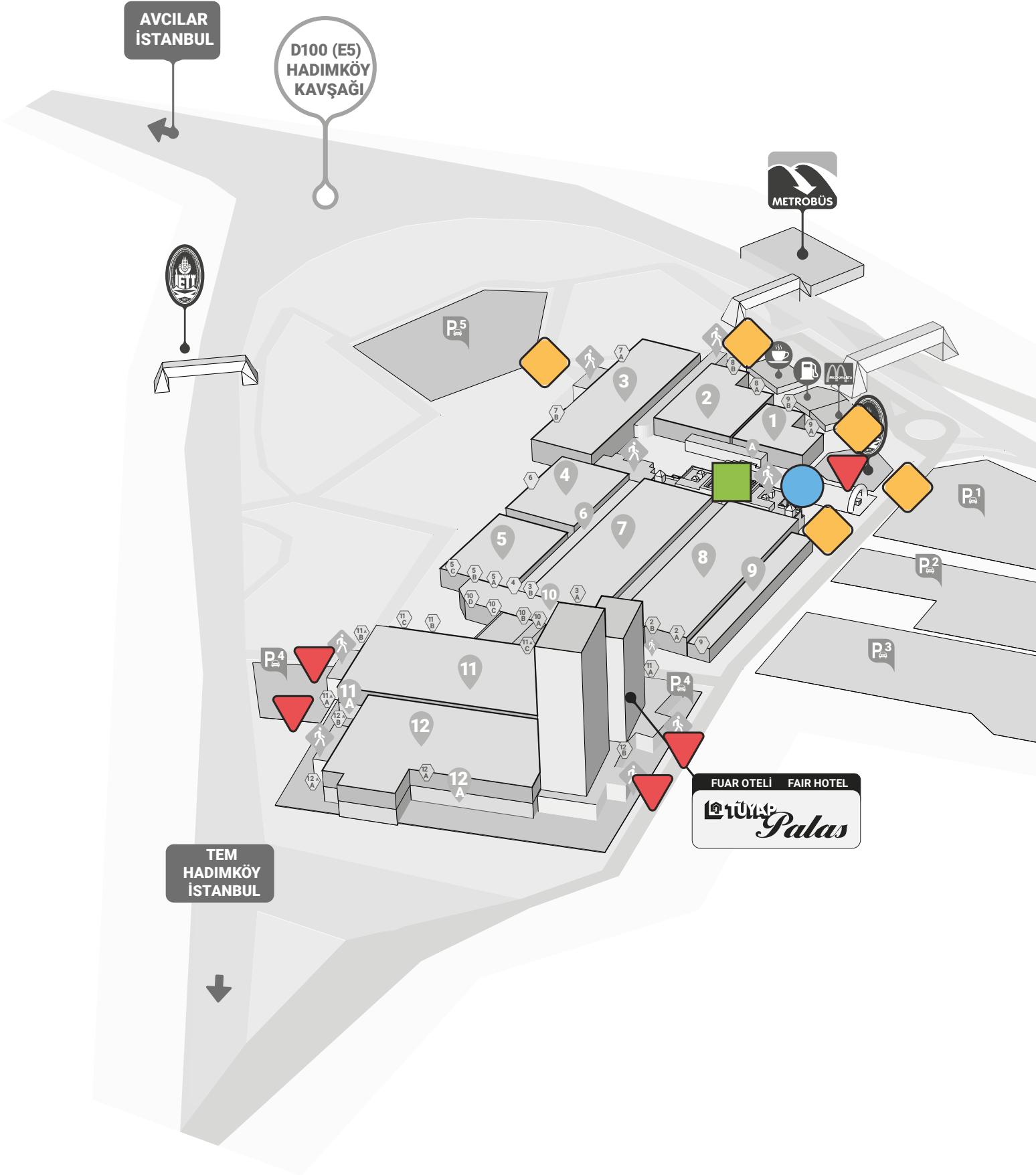



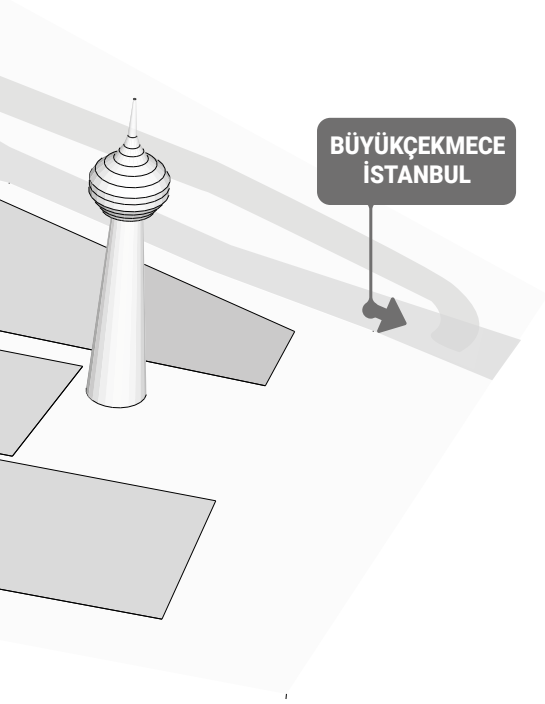

# OUTDOOR ADS AREA



BILLBOARDS 

FLAGPOLES 

COLUMN WRAPPING 

SYMBOL	PRODUCT CATEGORIES	WEST1 ENTRANCE	SOUTH ENTRANCE	WEST 1 CAR PARK	SERVICE AREA	EAST1 ENTRANCE	HALL 11 ENTRANCE	HALL 12 ENTRANCE	HALL 11A ENTRANCE	HALL 12A ENTRANCE
	BILLBOARDS	1 UNIT	2 UNIT	1 UNIT	5 UNIT	2 UNIT	-	-	-	-
	SAIL FLAG	3 LINE	-	2 LINE		-	-	-	-	-
	FLAGPOLES	10 PAIR	-	-		-	4 PAIR	4 PAIR	4 PAIR	4 PAIR
	COLUMN WRAPPING	7 UNIT	-	-		-	-	-	-	-



**Size:**  
1,50 m (width)  
4,00 m (height)

Location : West 1 Entrance  
**FLAGPOLES**

On the route used intensely by exhibition visitors and exhibitors for entrances to exits from the exhibition hall on foot or by vehicles.

Banner hanging is the organizer's responsibility.  
Design and print will be handled by the advertiser.  
Totally 7 flags allocated.  
Minimum 2, maximum 7 flags can be rented by per company

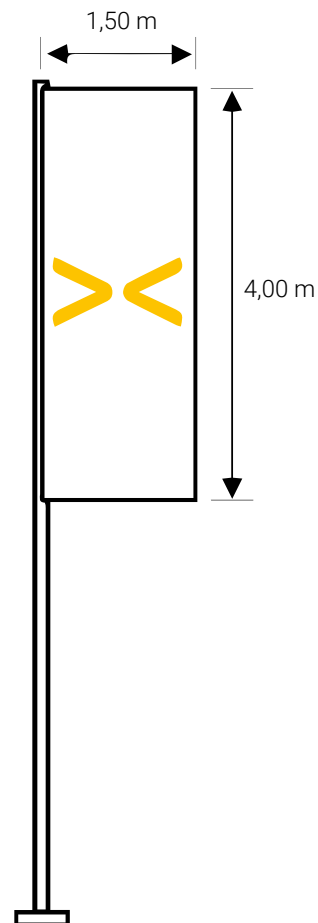

**Lease Cost (During Exhibition)**

2 poles	:	750 Euro + VAT
4 poles	:	1.375 Euro + VAT
6 poles	:	1.800 Euro + VAT
7 poles	:	2.200 Euro + VAT



Flag fabric double-sided printing.  
Design should be vertical.



**Size:**  
1,50 m (width)  
4,00 m (height)

Location : Hall 11 & 11A Entrance  
**FLAGPOLES**

Providing companies the opportunity to draw attention of visitors even before they enter the exhibition area, flagpoles at the entrances to the 11<sup>th</sup> Halls will offer significant benefits. To have your pennant on the poles in limited numbers will enhance your company's prestige at the exhibition grounds.

Banner hanging is the organizer's responsibility.  
Design and print will be handled by the advertiser.  
Minimum 2, maximum 8 flags can be rented by per company

**Lease Cost (During Exhibition)**

2 poles	: 625 Euro + VAT
4 poles	: 1.125 Euro + VAT
6 poles	: 1.500 Euro + VAT
8 poles	: 1.875 Euro + VAT



Flag fabric double-sided printing.  
Design should be vertical.

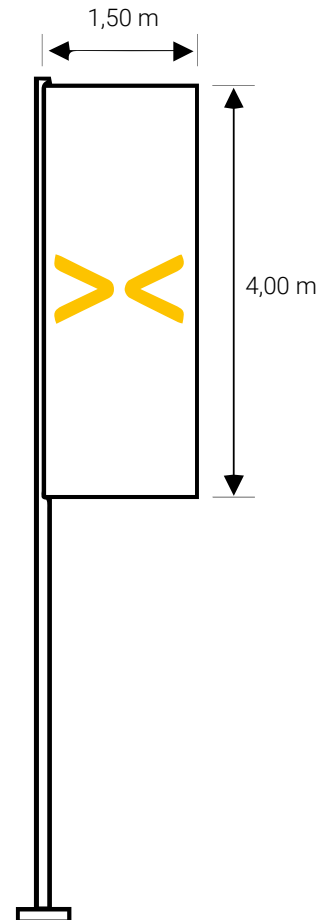

**ITM-B02**



**Size:**  
1,50 m (width)  
4,00 m (height)

## Location : Hall 12 & 12A Entrance

# FLAGPOLES

Providing companies the opportunity to draw attention of visitors even before they enter the exhibition area, flagpoles at the entrances to the 12<sup>th</sup> Halls will offer significant benefits. To have your pennant on the poles in limited numbers will enhance your company's prestige at the exhibition grounds.

Banner hanging is the organizer's responsibility. Design and print will be handled by the advertiser. Minimum 2 and maximum 7 units can be rented per company

### Lease Cost (During Exhibition)

2 poles	:	750 Euro + VAT
4 poles	:	1.375 Euro + VAT
6 poles	:	1.800 Euro + VAT
7 poles	:	2.200 Euro + VAT



Flag fabric double-sided printing.  
Design should be vertical.

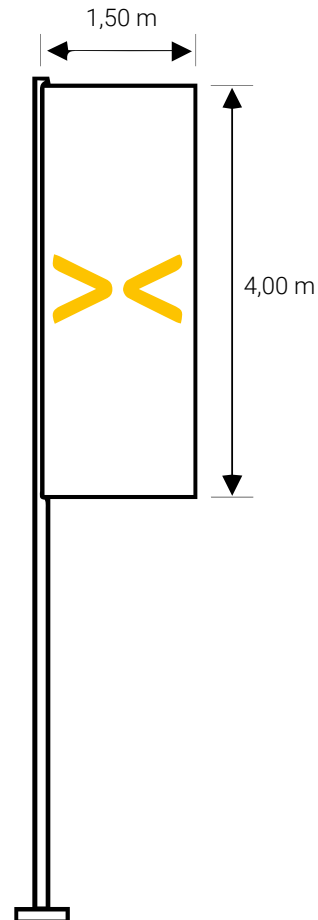



**ITM-B03**



**Size:**  
3,40 m (width)  
2,00 m (height)

Location : West 1 Entrance

## VISITOR SERVICE AREA BILLBOARDS

Billboards, Tüyap Fair and Congress Centre main entrance is located opposite the door. These boards can be used effectively by brands that want to reach dense consumer masses, it is located in the conspicuous place of the waiting area where fair visitors collectively spend an average of 15-20 minutes to wait for the departure time of the transport vehicles.

Banner hanging is the organizer's responsibility.  
Design and print will be handled by the advertiser.  
Minimum 2 and maximum 5 units can be rented per company.

### Lease Cost (During Exhibition)

2 boards	: 1.125 Euro + VAT
3 boards	: 1.500 Euro + VAT
4 boards	: 1.750 Euro + VAT
5 boards	: 2.000 Euro + VAT

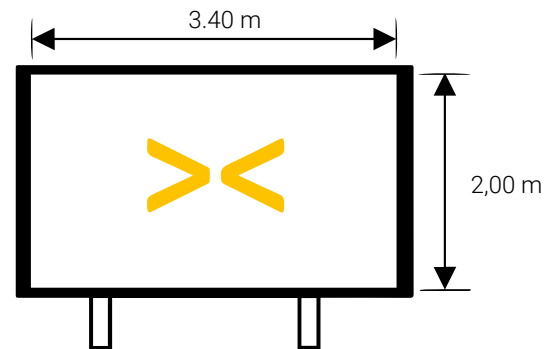

One piece of vinyl paulin.  
Design should be horizontal.



**Size:**  
3,40 m (width)  
2,00 m (height)

Location : East 1 Entrance

## EAST CAR PARK BILLBOARD

These billboards are the advertising panels located between the road connecting Tüyap Convention Center to E-5 highway and the East car park, which is intensely used by exhibitors and visitors. Attracting the attention of all visitors making their entrances through the East Car Park and allowing the companies to make their message heard in a very effective way, this is an advertising medium available to be seen from a broad perspective.

Banner hanging is the organizer’s responsibility.  
Design and print will be handled by the advertiser.  
There are 2 panels in total.

### Lease Cost (During Exhibition)

1 board	: 500 Euro + VAT
2 board	: 875 Euro + VAT

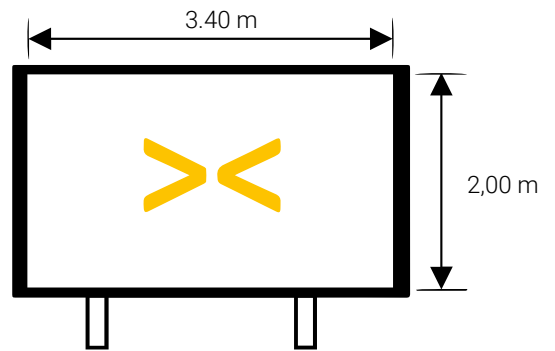

One piece of vinyl paulin.  
Design should be horizontal.



**Size:**  
95 cm (width)  
2,38 m (height)

Location : West 1 Entrance

## OUTER COURT COLUMNS WRAPPINGS

Columns are located the main entrance of the fair area, are in a central location that will attract the attention of all exhibitors and visitors to the fair.

Banner hanging is the organizer's responsibility.  
Design and print will be handled by the advertiser.

There are 2 columns in total (4 sides)

### Lease Cost (During Exhibition)

1 column	: 1.625 Euro + VAT
2 column	: 3.000 Euro + VAT

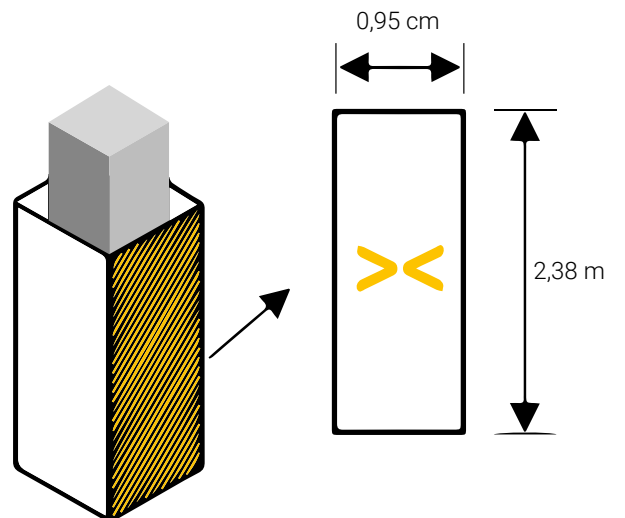

Laminated foil print (adhesive)  
Design should be vertical.

**ITM-B06**



**Size:**  
6,00 m (width)  
3,00 m (height)

Location : West 1 Car Park Entrance

## MEGABOARD

Megaboard is an illuminated large-size advertising board that is located at the car park entrance heavily used by the visitors, on the route connecting Tüyap Convention and Congress Center to the ring road across the waiting area for visitors arriving by Tüyap shuttles and public transport vehicles.

Banner hanging is the organizer's responsibility.  
Design and print will be handled by the advertiser.

### Lease Cost (During Exhibition)

Single Face : 3.750 Euro + VAT

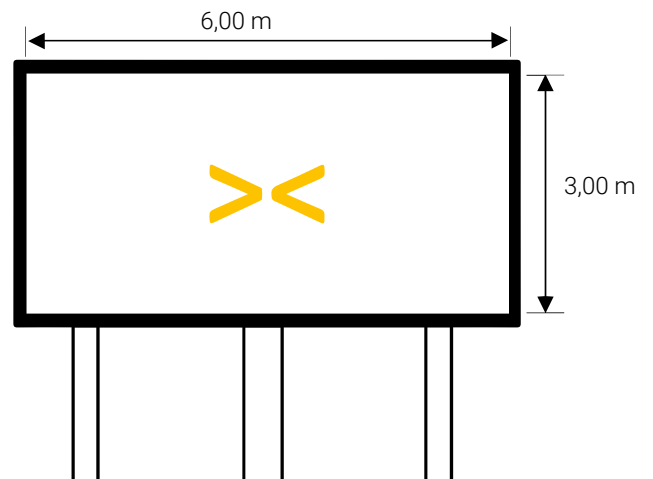

Printing on vinyl paulin.  
10 cm margin should be left on each side.  
Design should be horizontal.



**Size:**  
7,00 m (width)  
2,00 m (height)

Location : South Entrance

## VISITOR ENTRANCE BILLBOARDS

You can be the first to attract the attention of visitors by placing your advertisement on the 7 meter billboard in front of the South (Metrobus) gate, which is one of the entrances that visitors use intensively. It is an ideal medium to highlight your company and its new products.

Delivery Date: It must be delivered to the Technical Office at least 1 week before the opening day of the exhibition.

Implementation: Design and printing belongs to the advertiser. The organizer is responsible for hanging and dismantling.

### Lease Cost (During Exhibition)

1 billboard : 2.500 Euro + VAT



Printing on vinyl paulin.  
Design should be horizontal

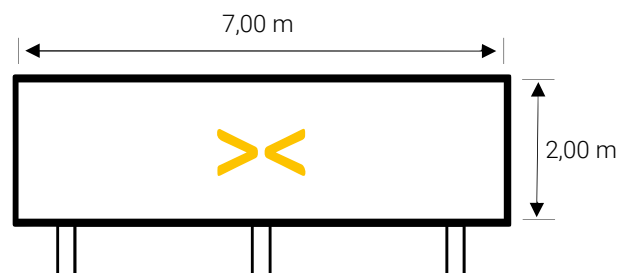





**Size:**  
3,50 m (width)  
2,00 m (height)

## Lokasyon : West 1 Entrance

# VISITOR ENTRANCE BILLBOARD

It is located in a remarkable position in the courtyard, where exhibitors, visitors, and protocol guests enter and exit the exhibition area intensively on foot and by vehicle. It is one of the most prestigious and effective advertising applications for companies that want to strengthen brand awareness.

Delivery Date: It should be delivered to the Technical Office 1 week before the opening day of the exhibit.

Implementation: The organizer is responsible for hanging and dismantling.

### Lease Cost (During Exhibition)

1 billboard :2.500 Euro + VAT

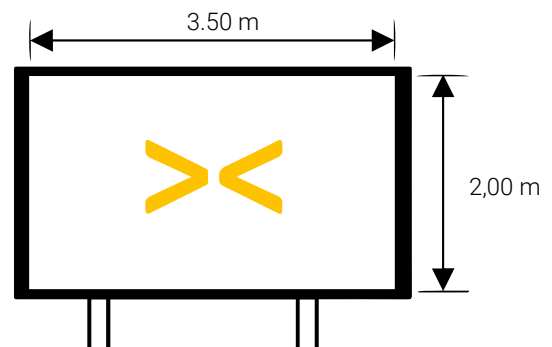

Printing on vinyl paulin.  
Design should be horizontal

# INDOOR ADS AREA

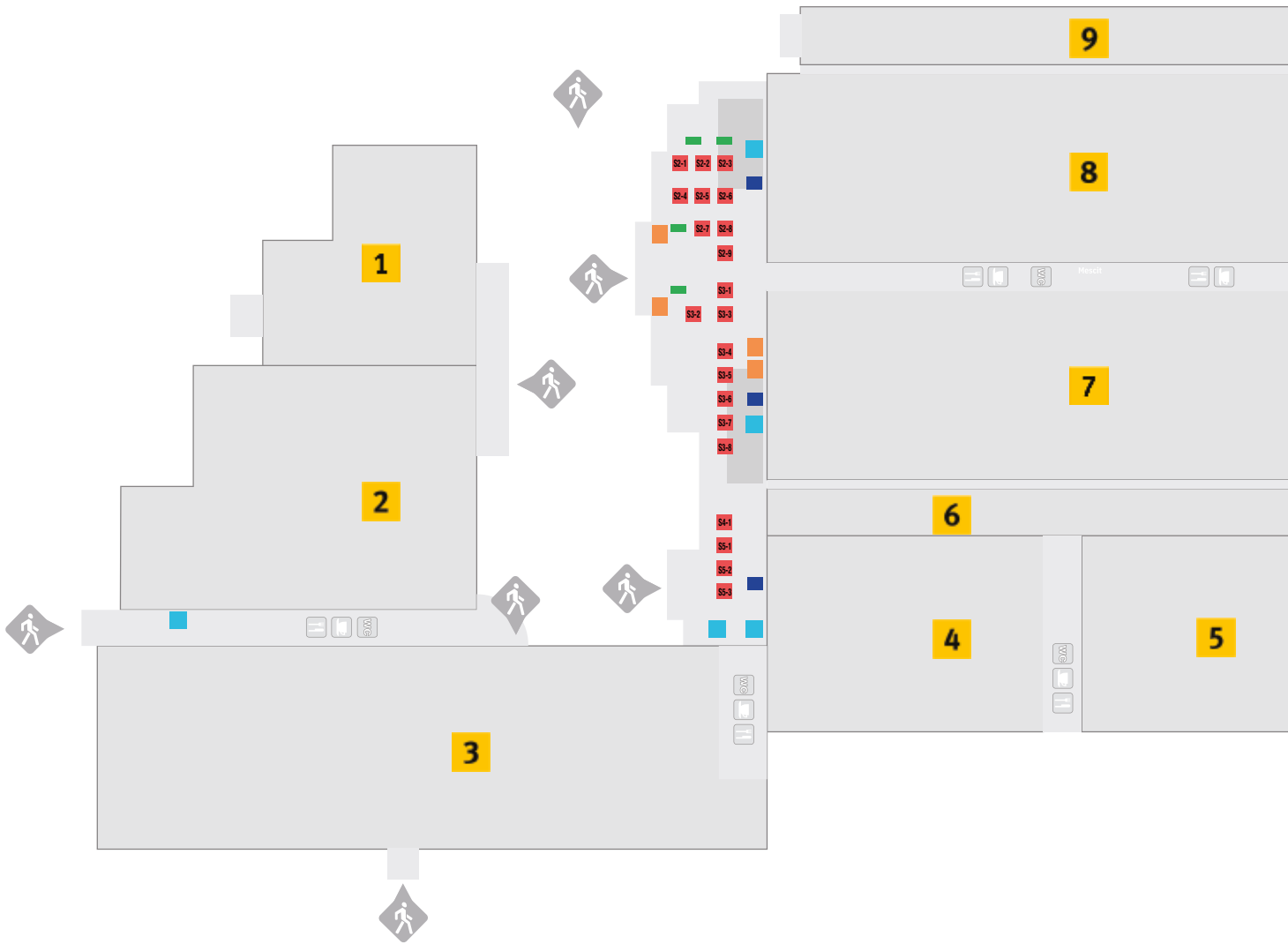

## ILLUMINATED WALL PANELS

LOCATION	UNIT
HALL 7 ENTRANCE	2
WEST 1 REGISTRATION AREA	2
HALL 11 FOYER	2
HALL 12 FOYER	4
HALL 11 A ENTRANCE	2
HALL 12 A ENTRANCE	2

## TEXTILE BOX

LOCATION	UNIT
HALL 8 ENTRANCE	1
HALL 7 ENTRANCE	1
HALL 6 ENTRANCE	1
HALL 3 ENTRANCE	1
HALL 11 ENTRANCE	1
HALL 2 ENTRANCE	1

## FOYER CEILING

LOCATION
WEST 1 FOYER

## BILLBOARDS

LOCATION
10-11A TRANSITION ESCALATORS

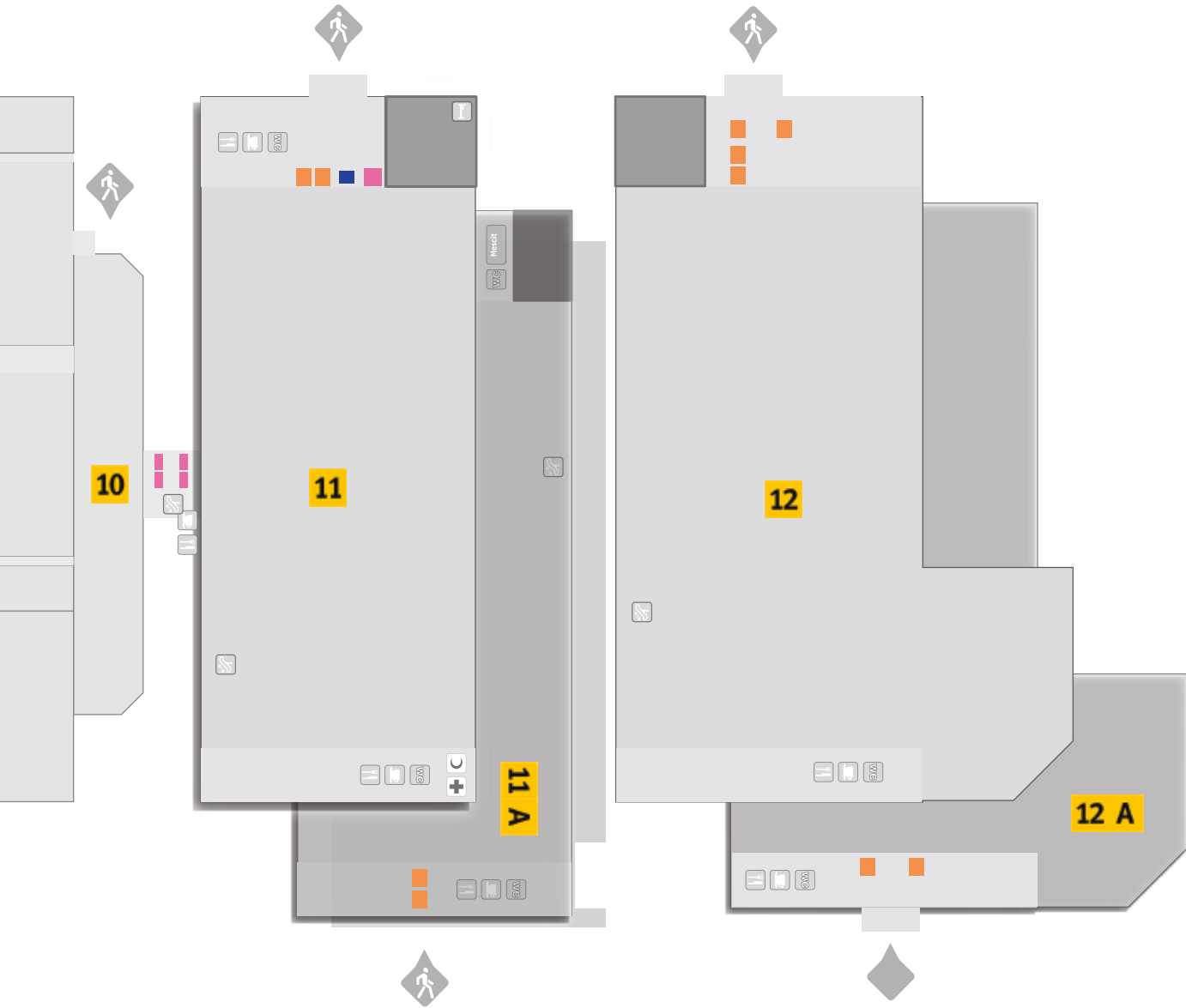

**NG- HANG ADS**

UNIT
4

UNIT
4

**COLUMN WRAPPING**

LOCATION	UNIT
WEST 1 FOYER REGISTRATION AREA	Group (3Column)
HALL 7-8 FOYER	12
WEST 1 FOYER CORRIDOR	5
TINY FOYER AREA	4

**LCD SCREEN**

LOCATION	UNIT
HALL 11 FOYER	1
HALL 8 ENTRANCE	1
HALL 7 ENTRANCE	1
HALL 6 ENTRANCE	1





**Size 1:**  
1,02 m (width)  
2,50 m (height)

**Size 2:**  
1,30 m (width)  
2,50 m (height)

Location : West 1 Foyer

## COLUMN WRAPPING

Column wrapping is an advertising solution that is applied on four sides of columns located behind the entrance turnstiles where visitors gather in crowds. They create an effective advertising media which grab the attention of all the visitors and exhibitors coming in and out of the hall and making use of info desks, cafes, press room and VIP hall including the protocol.

Delivery Date: It should be delivered to the Online 1 week before the opening day of the exhibit.

Implementation: The organizer is responsible for hanging and dismantling.

### Lease Cost (During Exhibition)

1 column	: 1.000 Euro + VAT
2 columns	: 1.750 Euro + VAT
3 columns	: 2.600 Euro + VAT
4 columns	: 3.300 Euro + VAT

Covering of all 4 sides of a column is included in the price.

Total number of columns are 12.

**S2-1-2-3-4-5-6-7-8-9 - S3-1-2-3**



Laminated foil printing (adhesive)  
Design should be vertical.

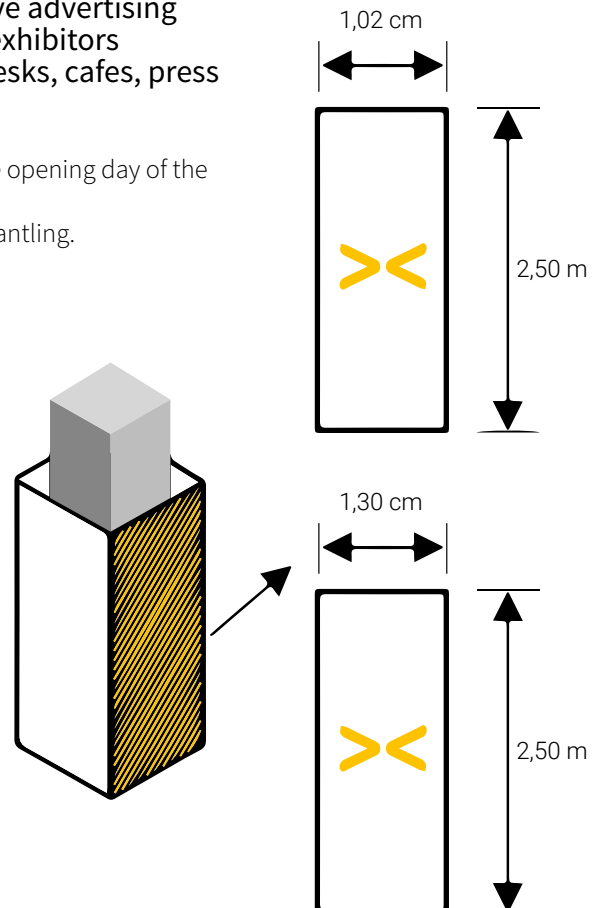



**Size 1:**  
1,02 m (width)  
2,50 m (height)

**Size 2:**  
1,30 m (width)  
2,50 m (height)

Location : West 1 Foyer Corridor

## COLUMN WRAPPING

Column wrapping is an advertising solution that is applied on four sides of columns located behind the entrance turnstiles where visitors gather in crowds. They create an effective advertising media which grab the attention of all the visitors and exhibitors coming in and out of the hall and making use of info desks, cafes, press room and VIP hall including the protocol.

Delivery Date: It should be delivered to Online one week before the opening day of the fair.

Implementation: The organizer is responsible for hanging and dismantling.

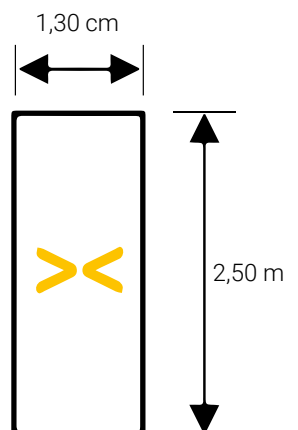
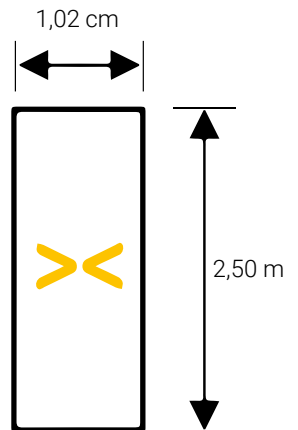

### Lease Cost (During Exhibition)

1 column	: 1.000 Euro + VAT
2 columns	: 1.750 Euro + VAT
3 columns	: 2.600 Euro + VAT
4 columns	: 3.300 Euro + VAT
5 columns	: 3.900 Euro + VAT

Covering of all 4 sides of a column is included in the price. Total number of columns are 5.

S3-4-5-6-7-8

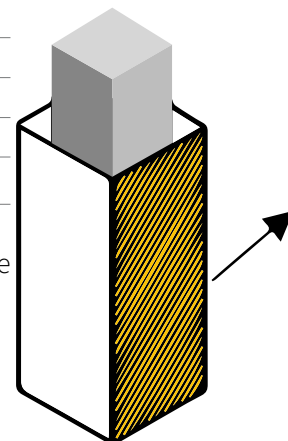

Laminated foil printing (adhesive)  
Design should be vertical



**Size 1:**  
1,02 m (width)  
2,50 m (height)

**Size 2:**  
1,30 m (width)  
2,50 m (height)

Location : West 1 Tinny Foyer Area  
**COLUMN WRAPPING**

Column wrapping is an advertising solution that is applied on four sides of columns located behind the entrance turnstiles where visitors gather in crowds. They create an effective advertising media which grab the attention of all the visitors and exhibitors coming in and out of the hall and making use of info desks, cafes, press room and VIP hall including the protocol.

Delivery Date: It should be delivered to Online one week before the opening day of the fair.  
Implementation: The organizer is responsible for hanging and dismantling.

**Lease Cost (During Exhibition)**

1 column	: 1.000 Euro + VAT
2 columns	: 1.750 Euro + VAT
3 columns	: 2.600 Euro + VAT
4 columns	: 3.300 Euro + VAT

Covering of all 4 sides of a column is included in the price.  
Total number of columns is 4.

**S4-1-2-3-4**



Laminated foil printing (adhesive)  
Design should be vertical.

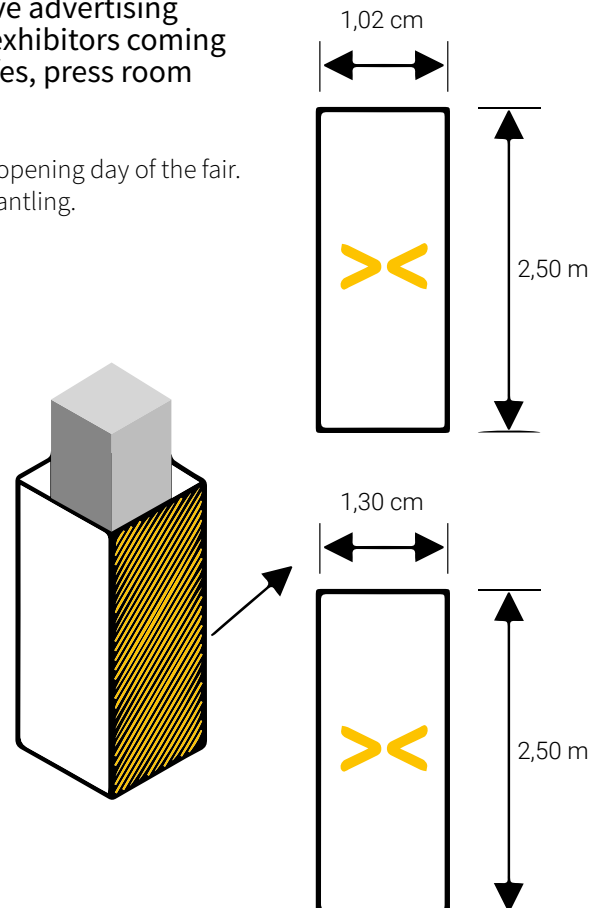

**ITM-C02**



**Size :**  
1,20 m (width)  
2,00 m (height)

Location : West 1 Foyer

## ILLUMINATED WALL PANELS

Illuminated wall panels located at the West 1 foyer entrance of Hall 7 are one of the important transition points of the exhibition center and are connected to other halls between the busy entrance-exit area of visitors and exhibitors. Hanging just beside the meeting hall and the café entrance, these panels are the advertising channels that will help your company to meet up with its target audience by drawing all the attention to themselves at a glance with their illumination, sizes and positions.

Banner hanging is the organizer's responsibility.

Design and print will be handled by the advertiser.

Delivery Date: It should be delivered to Online one week before the opening day of the fair.

### Lease Cost (During Exhibition)

1 Illuminated Wall Panels : 1.875 Euro + VAT

2 Illuminated Wall Panels : 3.125 Euro + VAT

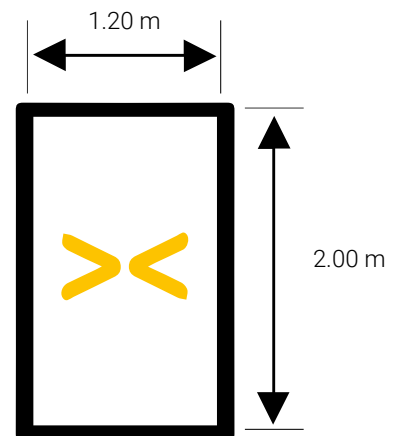

Duratrans printing  
Design should be vertical.



**Size:**  
2,00 m (width)  
3,00 m (height)

Location : Above and Next to the Exhibitor Booth and Corridor

## HANGING BANNERS ABOVE BOOTHS

These are the banners that will be hang over your booth area. They are effective advertising tools which ensure that visitors entering the hall are easily able to spot your company's location. In a sense, it is a distinctive visual tool ensuring that firms can draw all visitors to the exhibition to their booths by hanging their distinguished symbols above them.

Banner hanging is the organizer's responsibility.  
Design and print will be handled by the advertiser.  
Hanging banners are printed on front and back face.  
Delivery Date: It should be delivered to Online one week before the opening day of the fair.

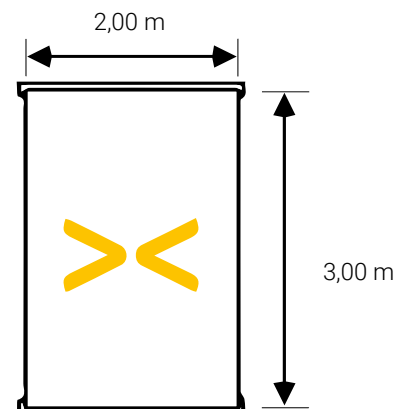

### Lease Cost (During Exhibition)

Above-Booth Banners : 1.250 Euro + VAT / Banner



Blackout printing/ Vinyl should be double sided piping from top and bottom side  
Design should be vertical.

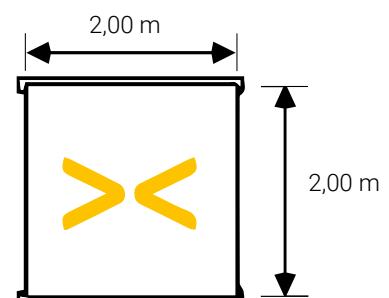





**Sizes:**

- 1-**  
5,00 m (width)  
2,35 m (height)
- 2-**  
2,50 m (width)  
2,35 m (height)

Location : Main Entrances

## EXHIBITION HALL MAIN ENTRANCE SPECIAL ADVERTISING AREAS

These are the special advertising areas by which all the exhibitors and visitors to the Halls 8-7-6-5-4-3-2 and 1 will pass through the main entrance. This is the right advertising media if you want your prestigious brand to appear at noticeable spots.

Banner hanging is the organizer's responsibility.

Design and print will be handled by the advertiser.

Delivery Date: It should be delivered to Online one week before the opening day of the fair.

### Lease Cost (During Exhibition)

Advertising Area for TYPE I	4.350 Euro + VAT
Advertising Area for TYPE II	2.750 Euro + VAT

#### 8<sup>th</sup>-7<sup>th</sup>-6<sup>th</sup>-5<sup>th</sup>-4<sup>th</sup> Hall Entrances

Advertising Areas for TYPE I

Advertising Areas for TYPE II

#### 3<sup>rd</sup>-2<sup>nd</sup>-1<sup>th</sup> Hall Entrances

Advertising Areas for TYPE I

Advertising Areas for TYPE II

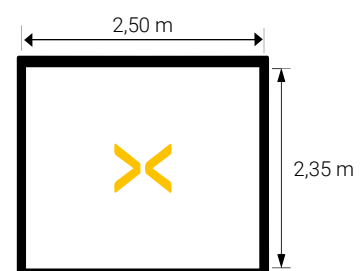
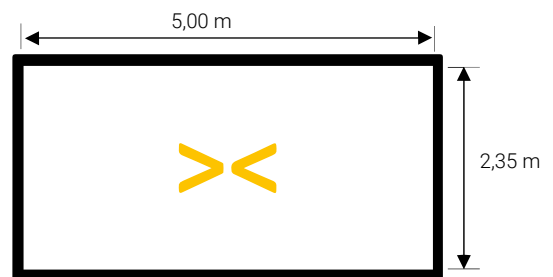

Vinyl Printing.  
Design should be horizontal or square.



Location : Registration Area

## INDOOR AREA ALLOCATION PLAN LOGO ADS

Boards of Exhibition Layout is a guide frequently consulted by visitors to find out the spots of the booths of companies they want to visit and the halls of events such as seminars, conferences which they wish to attend. Placing ads on layout boards, you can ensure that your brand will be prominent and your booth will draw more visitors.

Ad placing and application is the organizer's responsibility. Each company is allowed to place their ad only on the layout where its booth stands.

### Lease Cost (During Exhibition)

1 Logo : 625 Euro + VAT



**Size:**  
10 cm (width)  
6 cm (height)

Logo inside your  
own booth  
**LOGO**  
B:201

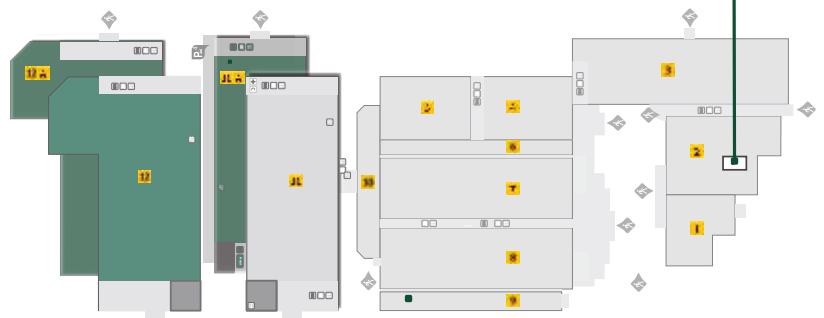

Your logo should be vectorial.



**Size:**  
1,40 m (width)  
2,81 m (height)

Location : Main Entrances

## HALL ENTRANCES ADVERTISING PANELS

This advertising area is placed next to the floor plan and exhibitor list at the Entrance of each Hall. Your message on this illuminated, one side and large size advertising tool will easily reach your target group thanks to its eye-catching nature.

This advertising area at each hall entrance can only be rent by 1 company.  
Ad placing is the organizer's responsibility.  
Design and print will be handled by the advertiser.

### Lease Cost (During Exhibition)

1 panel : 3.125 Euro + VAT

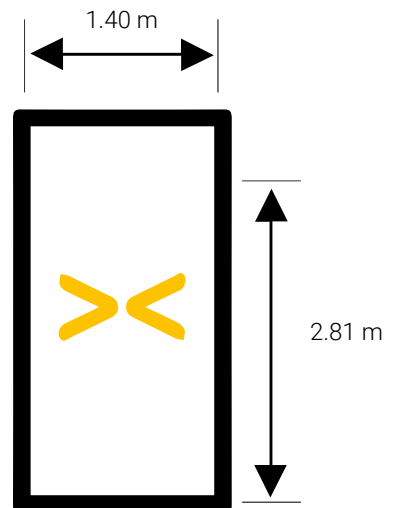

Laminated foil printing (adhesive).  
Design should be vertical.





**Size:**  
0,94 m (width)  
1,90 m (height)

Location : Main Entrance

## COLUMN WRAPPING

Column wrapping is an advertising solution that is applied on four sides of columns located at the Fair Main Entrance. This advertising area is uniquely placed directly at the main entrance behind the turnstiles, where it will grab the attention of all visitors and exhibitors entering and exiting the exhibition.

Only 1 column is available for this advertising area.  
Ad placing is the organizer's responsibility.  
Design and print will be handled by the advertiser.

### Lease Cost (During Exhibition)

1 Column : 3.125 Euro + VAT



Laminated foil printing (adhesive)  
Design should be vertical.

## ITM-C11



Location : Hall Entrances

## LCD SCREENS

High-resolution LCD screens positioned in the main entrances which is crossing area from the foyer areas to the exhibition halls offer the most innovative and striking advertising channels of the exhibition center.

**Useable Item:** Maximum 8 ad slots per screen. Ads can take place on each screen with a maximum of 2 ad slots. Your 20-second video ad will be broadcast on all screens once every three minutes. During the hours when the fair is open to visitors, the advertisement broadcast continues uninterruptedly.

**Sizes:** 75 inch Vertical LCD Screen, Resolution: 1080x 1920 px  
Material & Technical Information: Jpg, mpeg or m4 video format  
Motion or static content can be used.

**1080 x 1920 px**

### Lease Cost (During Exhibition)

2-3-7-12 Hall Entrances

20 sec. Advertising Slot

3.200 Euro + VAT

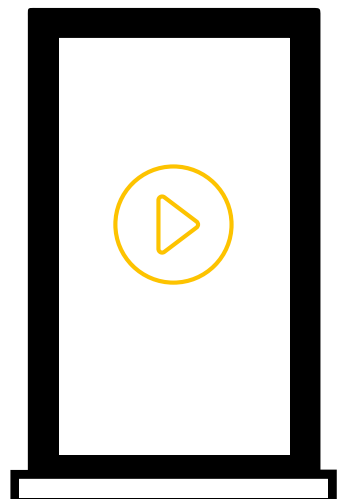



**Size:**  
6,00 m (width)  
2,00 m (height)

**HALL 8**

Location : Hall Entrances

# TEXTILE BOX ADVERTISING BOARDS

At the entrances of exhibition halls 3, 7, 8 and 12 located, in large sizes and internally lighted with heated textile printing applications are quite remarkable advertising practices.

- Hall 3 Size: 5m x 2m**
- Hall 7 Size: 3m x 2m**
- Hall 8 Size: 6m x 2m**
- Hall 12 Size: 2,35m x 4 m**

Each company can only advertise on the layout of the hall where their stand is located.

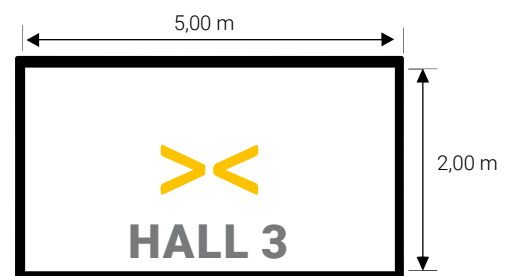

Internally illuminated fabric print.  
Design should be horizontal.  
2,5cm carded in measure.



**Size:**  
5,00 m (width)  
2,00 m (height)

**HALL 3**



**Size:**  
3,00 m (width)  
2,00 m (height)

**HALL 7**

Hall 2 Foyer Entrance, Hall 3 Foyer Entrance,  
Hall 7 Foyer Entrance, Passage between Halls 10-12

**Useable Item:** There are 1 panel each in 4 different location.

### Lease Cost (During Exhibition)

3-7-8-12. Hall Entrances

Hall 3 TextileBox	4.750 Euro + VAT
Hall 7 Textile Box	3.750 Euro + VAT
Hall 8 Textile Box	5.000 Euro + VAT
Hall 12 Textile Box	3.500 Euro + VAT

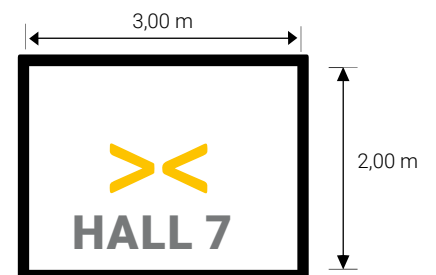



**ITM-C02**



**Size:**  
1,20 m (width)  
2,00 m (height)

Location : 11-11A-12-12A Foyers

## ILLUMINATED WALL PANELS

Illuminated wall panels are one of the important transition points of the exhibition center and are connected to other halls, between the busy entrance-exit area of visitors and exhibitors. The lighting located right next to the entrance of the meeting hall and cafeteria is an advertising medium that will help your company meet its target audience by attracting the attention of the masses in a short time with its size and location.

**Hall 11 Size: 120 cm X 200 cm (2 items Verticals)**  
**Hall 11A Size: 195cm X 115 cm (2 items pieces vertical)**

**Hall 12 Size: 200 cm X 120 cm (2 items Horizontal)**  
**Hall 12 Size: 120 cm X 200 cm (2 items Pieces Vertical)**

**Hall 12A Size: 200 cm X 120 cm (1 item Horizontal)**  
**Hall 12A Size: 120 cm X 200 cm (2 items Vertical)**

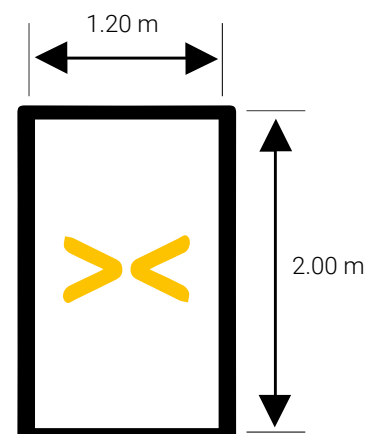
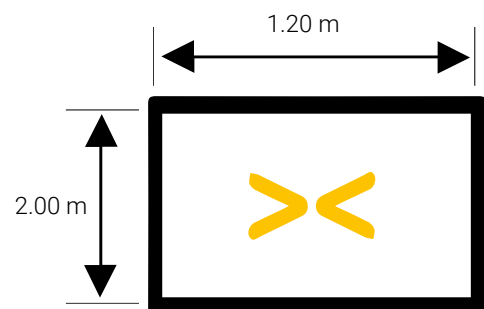

### Lease Cost (During Exhibition)

1 Illuminated Wall Panel	: 1.875 Euro + VAT
2 Illuminated Wall Panel	: 3.125 Euro + VAT



Duratrans printing.  
Design should be vertical



**ITM-C06**



**Size:**  
2,00 m (width)  
5,00 m (height)

Location : Foyer

## FOYER CEILING-HANG ADS

Foyer Ceiling-Hang advertising includes applications of various designs for the promotion of your company in foyers receiving intense visitors. If you want to have your brand at a prominent point in the prestigious foyer of the exhibition center, which also incorporates Press and VIP rooms, this will be the best advertising solution for you to choose.

Ad hanging is the organizer's responsibility.  
Design and print will be handled by the advertiser.  
Minimum 2, maximum 4 banners can be rented by per company

### Lease Cost (During Exhibition)

1 Banner : 2.000 Euro + VAT

2 Banners: 3.750 Euro + VAT

3 Banners: 5.250 Euro + VAT

4 Banners: 6.750 Euro + VAT

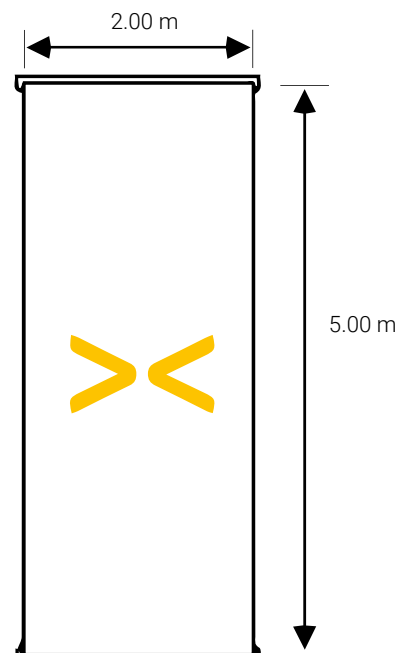

Blackout printing  
Vinyl Single Sided tubular by top and bottom  
Design should be vertical





Location : 10-11A Transition Escalators

## ILLUMINATED WALL PANELS

11 and 11A are illuminated wall panels located on both sides of the escalators that provide access to halls 11 and 11A. Sold in 4 pieces, they are ideal channels to highlight your products and brands and direct visitors to your booth.

**Delivery Date:** It must be delivered to Teknik Office at least one week before the start date of the fair installation.

**Implementation:** Design and printing belongs to the advertiser, the organizer is responsible for hanging.

### Lease Cost (During Exhibition)

1 Line (4 Panels)                      4.000 Euro + VAT

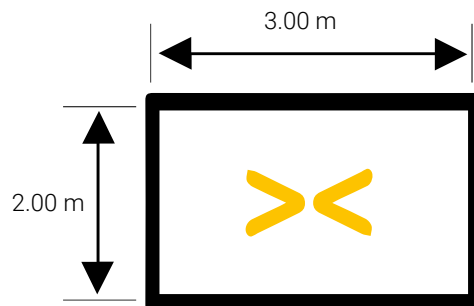

Horizontal printing on vinyl paulin  
Five centimeters of ground allowance  
should be left on each side.

ITM-C15



**Size:**  
40 cm (width)  
10 cm (height)

Location : Registration Areas

## JET PASS KIOSK ADVERTISEMENTS

These are the advertisements on the screens and on the Jet Pass kiosks that pre-registered visitors use to get their badges. Every year more and more visitors prefer online registration as it is the fastest and easiest way to enter the exhibition. Let your brand stricks in the minds of thousands of visitors with Jet Pass ads.

**Location:** All Entrances

**Usage:** Can only be sold to 1 company

**Advertisement Wrapping Area Size:** Please consult your sales representative.

**Material & Technical Information:** Advertising foil on the kiosk should be sticker printing.

**Delivery Date:** It must be delivered to the Technical Office at least 1 week before the opening day of the fair.

**Implementation:** Design and printing belong to the advertiser; the organizer is responsible for the implementation.

### Lease Cost (During Exhibition)

Advertisement on Kioks      3.000 Euro + VAT

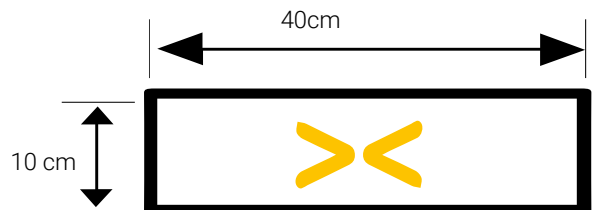

Laminated foil sticker.  
Design should be horizontal.



**ITM-D01**

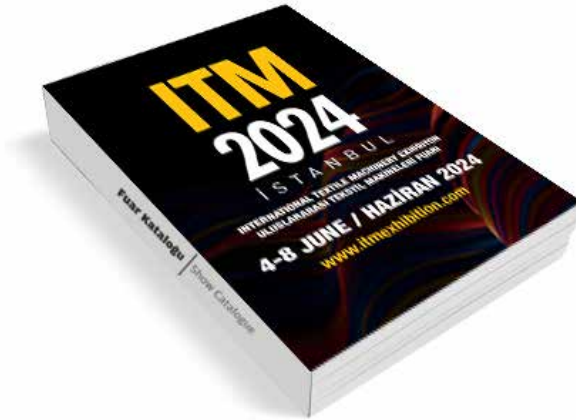

## (4 COLORS) CATALOGUE ADS

Exhibition catalogue is a desktop guide for the benefit of professionals, including product groups of the industry, domestic and foreign production, sales and service companies, representations, non-governmental organizations, public institutions, educational institutions and relevant publications. Through ads in the catalogues, your message will be conveyed to the industry professionals without time and place limitation, and at each use of catalogue, you will draw attention, stick in the mind and be remembered.

Design and print will be handled by the advertiser.

### Lease Cost (During Exhibition)

Back Cover	: 2.000 Euro +VAT
Front Cover Inside	: 1.000 Euro +VAT
Back Cover Inside	: 1.000 Euro + VAT
First Page	: 1.000 Euro + VAT
Two Adjoining Inner Pages	: 1.000 Euro + VAT
Single Inner Page	: 600 Euro + VAT
Inside-Catalogue Single Page Insert	: 1.000 Euro + VAT

Note: Special folding applications inside the catalogue or on covers will be extra priced.

**ITM-D05**



**Size: 12,5 cm (width) x 25 cm (height)**

## VISITOR GUIDE EXHIBITION LAYOUT ADS

Exhibition Layout-Visitor Guide are handed out at the entrances and all the information points for free. Exhibition Layout-Visitor Guide is a practical and useful guide that helps visitors to find out the spots of the booths of companies they want to visit and the halls of events such as seminars, conference which they wish to attend, and which they frequently resort throughout their exhibition tours. Placing ads on leaflets and layout is a practical advertising tool that will allow your brand to reach over the entire industry. It is therefore a practical guide that is consulted and used by all visitors. Advertising on the pages in this guide and/or on the plan of the hall you are in, on your stand, will be an effective promotion that will attract the attention of all visitors and ensure that your company is known by everyone:

A total of 60,000 copies will be printed.

Design and print will be handled by the advertiser.  
Total advertising space is 5 pieces.

### Lease Cost (During Exhibition)

1 <sup>st</sup> Page	: 6.000 Euro + VAT
Back Cover	: 7.500 Euro + VAT
Back Cover Inside	: 4.500 Euro + VAT
Single Inner Page	: 4.000 Euro + VAT
Logo on Floorplan	: 1.100 Euro + VAT

# ITM 2024 İSTANBUL

## AREA LOCATION MAP

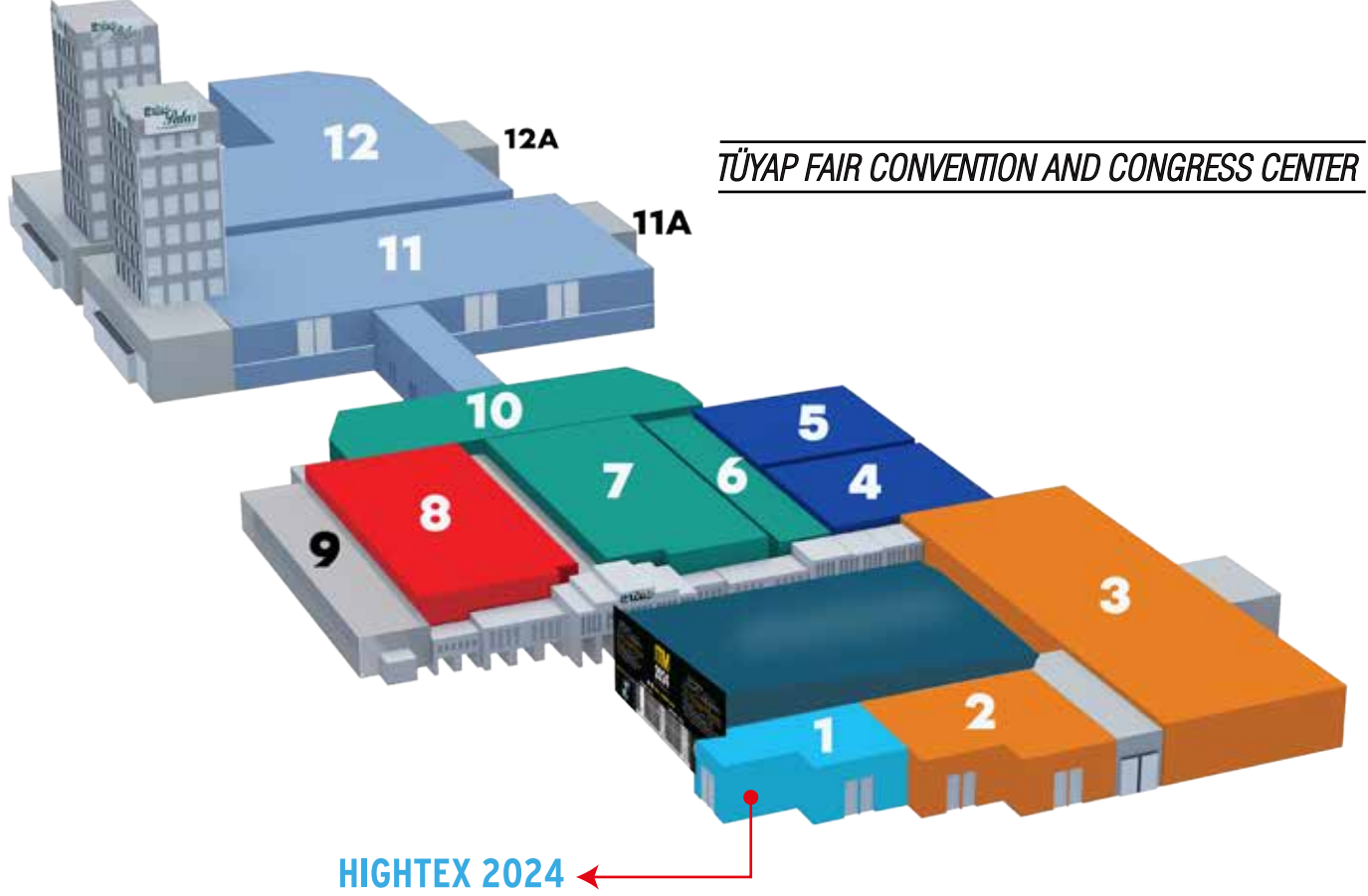

**TÜYAP FAIR CONVENTION AND CONGRESS CENTER**

**HIGHTEX 2024**

**HALL**

**1**

**HIGHTEX 2024**

INTERNATIONAL TECHNICAL TEXTILES AND NONWOVEN EXHIBITION

**HALL**

**2-3**

- Weft and Warp Knitting Preparation Machineries
- Flat and Circular Knitting Machineries
- Hosiery Machineries
- Embroidery Machineries
- Quilting Machineries
- Auxiliary Machinery, Spare Parts and Accessories

**HALL**

**4-5**

- Textile Printing Machineries
- Digital Textile Printing Machineries
- Textile Printing Dyeing & Chemicals
- Auxiliary Machinery, Spare Parts and Accessories

**HALL**

**6-7  
10**

- Cotton and Fibre Preparation Machineries
- Spinning Preparation Machineries
- Winding, Twisting and Texturing Machineries
- Nonwoven Machineries and Technologies
- Auxiliary Machinery, Spare Parts and Accessories

**HALL**

**8**

- Weaving Preparation Machineries
- Weaving Machineries
- Tufting and Carpet Weaving Machineries
- Narrow Weaving Machineries
- Cordage and Rope Machineries
- Auxiliary Machinery, Spare Parts and Accessories

**HALL**

**11-11A  
12**

- Yarn and Fabric Dyeing & Finishing Machineries
  - Washing, Bleaching, Drying Machineries
  - Folding and Rolling Machineries
  - Textile Chemicals, Laboratory Equipments and Quality Control Systems
  - CAD-CAM-CIM Applications & Automation Systems
  - Auxiliary Machinery, Spare Parts and Accessories
- DENIM TECHNOLOGIES**

Advertising Area Sales and Reservation



TÜYAP FAIRS INC.  
P : + 90 212 867 11 00  
F : + 90 212 886 66 98  
www.tuyap.com.tr

enesguney@teknikfuarcilik.com  
dilara@teknikfuarcilik.com



TEKNİK FAIRS INC.  
P : + 90 212 876 75 06  
F : + 90 212 876 06 81  
www.teknikfuarcilik.com